

INSTRUCTIONS FOR SAFE HANDLING

Name: **DIAPHRAGM CHECK VALVE TYPE MEVA**

- EN-GJS-400-15 (JS 1030): DN 40-400, PN 10, PN 16

The operating conditions must be in accordance with the manufacturer's Declaration of Performance.

1. PRODUCT INSTALLATION

Proper installation of the valve is a condition for trouble-free operation. The valve is flanged, installed between the flanges - installation in accordance with EN 558-1 series 48, screw connection and flange seals in accordance with DIN 2501 (depending on DN and PN).

The installation direction is indicated by a cast arrow on the valve body - it indicates the direction of flow of the medium. The valve can be installed in all positions. Before and behind the valve there should be at least 3xDN length of straight pipe. Optimal function of the valve is in area of water flow 2-4 m/s. Prior to installing the valve, the flow must be closed or the pipeline emptied and in case of higher temperature cooled to room temperature.

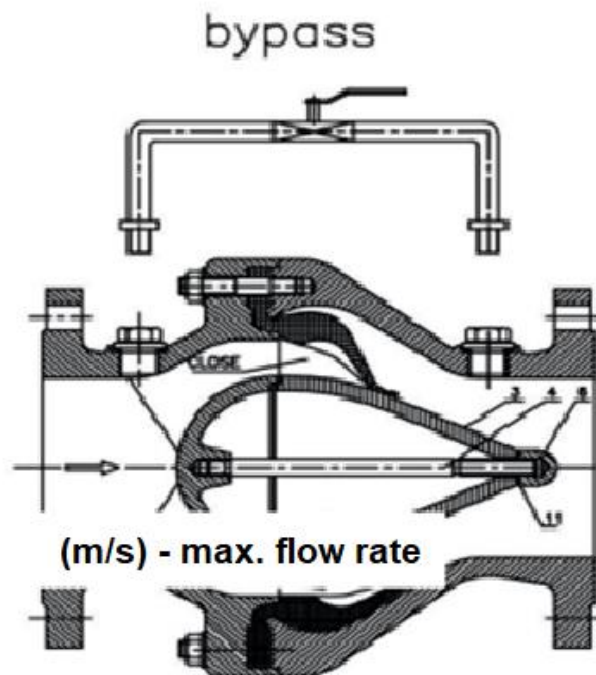

2. MAINTENANCE AND REPAIR

The diaphragm non-return valve - MEVA - is simple and does not require special maintenance. In the event of a leak or damage to the membrane seal, the valve must be removed from the pipeline. Before removing the valve from the pipeline, it must be emptied and cooled in case of higher temperature.

The procedure for replacing the membrane seal after dismantling from the pipeline is as follows:

- To service the valve, ensure a suitable working environment - place the valve in a vertical position,
- Unscrew the nuts (DN 50-150; 8) or screws (DN 200-400) and remove the inlet part with the guide (1),
- Remove the diaphragm seal (5) from the bearing and clean the guide (3) and the contact surface of the seal,
- Put a new diaphragm in the outlet part (2) - pre-lubricate the inner edge of the outlet part with silicone oil,
- Plant the inlet part (1) - making sure that the plugs (12) are vertically in the same line,
- Tighten the nuts (DN 50-150; 8) or screws (DN 200-400; 7) evenly so that the metal is pressed against the metal,
- Test the function of the valve and install it in the pipeline.

COMPONENT PARTS

POZICIJA	NAZIV	POZICIJA	NAZIV
1	INLET	8	NUT (ONLY DN 50-150)
2	OUTLET	9	WASHER
3	GUIDE	10	GASKET
4	BOLT	11	GASKET Cu
5	DIAPHRAGM	12	PLUG
6	CLOSED NUT	13	GASKET Cu
7	STUD BOLT / BOLT (DN 200-400)		

